

**640G3/648G3/460D
(604614-) Skidders**



JOHN DEERE

PARTS CATALOG

**640G3/648G3/460D
(604614-) Skidders
PC9515 (MAY-06)**

Worldwide Construction and Forestry Division

WORLDWIDE EDITION

customer service email: admin@servicemanualperfect.com

LITHO IN U.S.A. (REVISED)

1A2

640G-III/460DC CABLE AND 648G-III/460DG GRAPPLE SKIDDERS (S.N. 604614-)

640G-III/648G-III/460DC/460DG

PARTS CATALOG

INTRODUCTION AND CUSTOMER INFORMATION

TW54860 -UN-04APR06

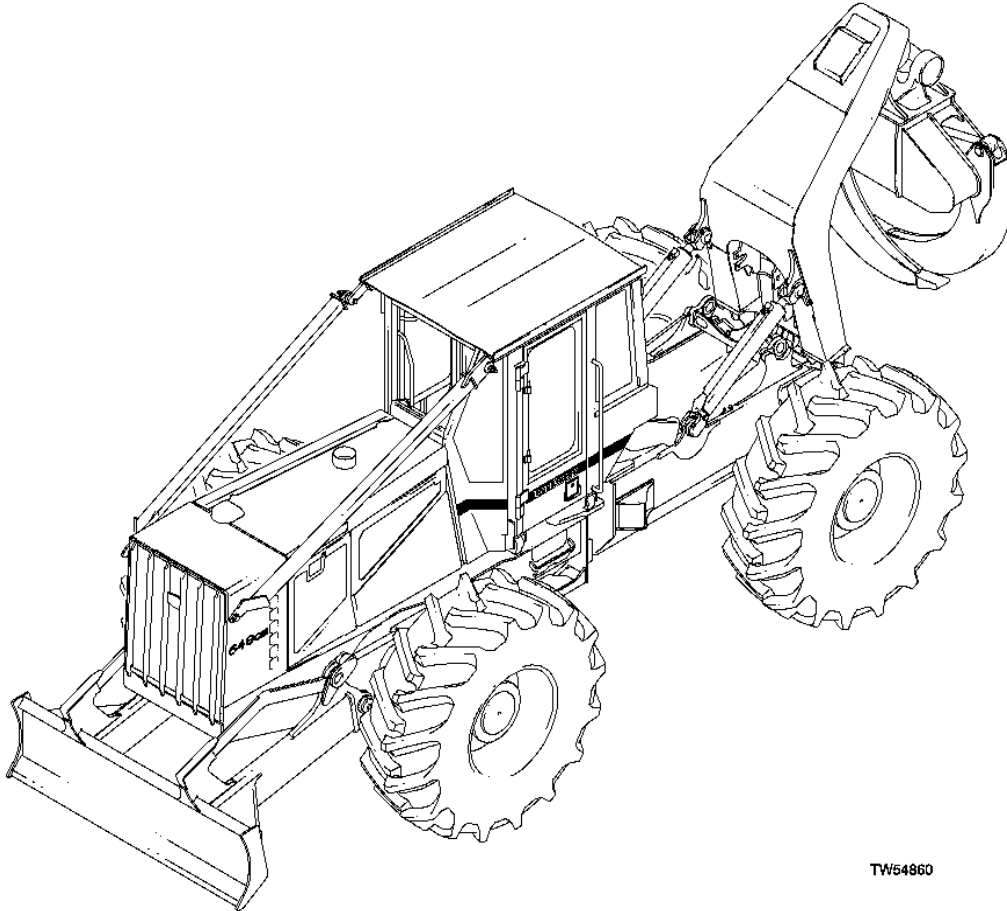

TW54860

*RIGHT SIDE VIEW OF JOHN DEERE 648G-III GRAPPLE SKIDDER
(MANUFACTURED 2006-)*

TO THE CUSTOMER

NOTE - THIS PARTS CATALOG INCLUDES 4 MODELS (640G-III/648G-III,460DC/460DG) WHERE APPLICABLE PART NUMBERS ARE INDICATED AS SUCH.

THE PART NUMBERS IN THIS PARTS CATALOG WERE CORRECT AT THE TIME YOUR CATALOG WAS PUBLISHED. IT IS OUR POLICY TO CONSTANTLY IMPROVE OUR MACHINES AND, THEREFORE, PART NUMBERS MAY CHANGE. WHEN ORDERING PARTS, VERIFY PART NUMBERS THROUGH YOUR DEALER.

(SPECIFICATIONS AND DESIGN SUBJECT TO CHANGE WITHOUT NOTICE.)

1A3

640G-III/460DC CABLE AND 648G-III/460DG GRAPPLE SKIDDERS (S.N. 604614-)

SERIAL NUMBER LOCATION

EACH 640G-III SKIDDER MAY HAVE FIVE SERIAL NUMBERS: ONE FOR THE PRODUCT IDENTIFICATION PLATE, ONE FOR THE CAB, ONE FOR THE ENGINE, ONE FOR THE HYDRAULIC PUMP AND ONE FOR THE WINCH.

THE PRODUCT IDENTIFICATION NUMBER PLATE IS LOCATED ON THE LEFT UPPER REAR CORNER OF ENGINE FRAME.

THE ENGINE SERIAL NUMBER PLATE IS LOCATED ON THE RIGHT-HAND SIDE OF THE CYLINDER BLOCK BEHIND THE ENGINE OIL FILTER.

THE HYDRAULIC PUMP SERIAL NUMBER PLATE IS LOCATED ON THE RIGHT-HAND SIDE OF THE HYDRAULIC PUMP.

THE WINCH SERIAL NUMBER IS LOCATED ON THE UPPER FRONT OF THE WINCH HOUSING.

EACH 648G-III GRAPPLE SKIDDER MAY HAVE FIVE SERIAL NUMBERS: ONE FOR THE PRODUCT IDENTIFICATION NUMBER, ONE FOR THE CAB, ONE FOR THE ENGINE, ONE FOR THE HYDRAULIC PUMP AND ONE FOR THE WINCH.

THE PRODUCT IDENTIFICATION NUMBER PLATE IS LOCATED ON THE UPPER REAR CORNER OF ENGINE FRAME.

THE ENGINE SERIAL NUMBER PLATE IS LOCATED ON THE RIGHT-HAND SIDE OF THE CYLINDER BLOCK BEHIND THE ENGINE OIL FILTER.

THE HYDRAULIC PUMP SERIAL NUMBER IS LOCATED ON THE RIGHT-HAND SIDE OF THE HYDRAULIC PUMP.

THE WINCH SERIAL NUMBER IS LOCATED ON THE UPPER FRONT OF THE WINCH HOUSING.

WHENEVER SERIAL NUMBERS ARE REQUIRED ON ALL WARRANTY CLAIMS OR CORRESPONDENCE PERTAINING TO THIS PRODUCT, IT IS EXTREMELY IMPORTANT THAT ALL CHARACTERS BE FURNISHED. THIS POINT CANNOT BE OVEREMPHASIZED.

**Thanks very much for your reading,
Want to get more information,
Please click here, Then get the complete
manual**

JustClickHere 

NOTE:

**If there is no response to click on the link above,
please download the PDF document first, and then
click on it.**

**Have any questions please write to me:
admin@servicemanualperfect.com**

1A4

640G-III/460DC CABLE AND 648G-III/460DG GRAPPLE SKIDDERS (S.N. 604614-)

PRODUCT IDENTIFICATION NUMBER
(640G-III AND 648G-III)

TP49688 -UN-07APR98

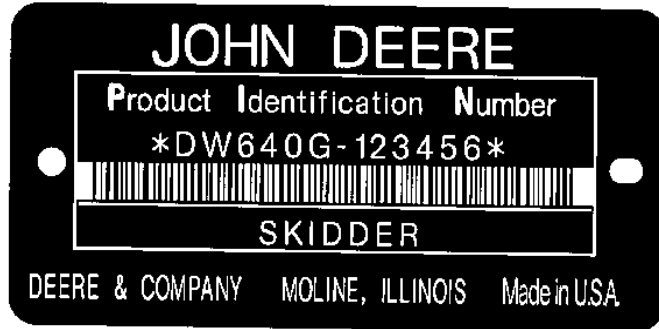

TP49688

1. DESIGNATES SKIDDER MANUFACTURER
2. DESIGNATES SKIDDER MODEL
3. DESIGNATES SKIDDER SERIAL NUMBER
4. DESIGNATES UNIT TYPE

DW - JOHN DEERE DAVENPORT WORKS
640G-III OR 648G-III
123456 (EXAMPLE)
SKIDDER OR GRAPPLE SKIDDER

PRODUCT IDENTIFICATION NUMBER
(460D)

T135317 -UN-07NOV00



T135317

1. DESIGNATES SKIDDER MANUFACTURER
2. DESIGNATES SKIDDER MODEL
3. DESIGNATES SKIDDER SERIAL NUMBER

DW - JOHN DEERE DAVENPORT WORKS
460D
123456 (EXAMPLE)

1A5

640G-III/460DC CABLE AND 648G-III/460DG GRAPPLE SKIDDERS (S.N. 604614-)

SERIAL NUMBER LISTING INFORMATION

SERIAL NUMBER INFORMATION IS LISTED TO SHOW ON WHICH MACHINES EACH PART CAN BE USED; FOR EXAMPLE:

- THE PART CAN BE USED ON ALL MACHINES.
- 000000- THE PART CAN BE USED ON ALL MACHINES BEGINNING WITH THE SERIAL NUMBER LISTED.
- 000000 THE PART CAN BE USED ON ALL MACHINES UP TO AND INCLUDING THE SERIAL NUMBER LISTED.
- 000000-000000 THE PART CAN BE USED ON ALL MACHINES BETWEEN AND INCLUDING THE SERIAL NUMBERS LISTED.

WHEN XXXXXX'S ARE LISTED IN PLACE OF A SERIAL NUMBER, A SERIAL NUMBER CHANGE WAS MADE BUT THE EXACT SERIAL NUMBER WAS NOT AVAILABLE WHEN THE CATALOG WAS PRODUCED.

DIRECTION ARROW

ARROWS ARE USED WITH ILLUSTRATIONS TO INDICATE THE FRONT OF THE UNIT. "RIGHT-HAND" AND "LEFT-HAND" SIDES ARE DETERMINED BY FACING IN THE DIRECTION OF MACHINE FORWARD TRAVEL.

BOX-ENCLOSED ILLUSTRATIONS

A KEY NUMBER, SHOWN IN THE PARTS LIST, IS ASSIGNED TO A BOX ENCLOSING ALL PARTS SOLD AS A SERVICE ASSEMBLY.

COMPLETE GOODS LISTINGS

COMPLETE GOODS ARE LISTED IN BOLD FACE TYPE. ORDER SEPARATELY. DO NOT INCLUDE ON REPLACEMENT PARTS ORDER.

SI UNITS OF MEASURE

METRIC DIMENSIONS ARE GIVEN, WHERE APPLICABLE, THROUGHOUT THIS PARTS CATALOG.

CHANGE INDICATOR LINE

CHANGES AFFECTING THE ORDERING OF PARTS ARE IDENTIFIED BY VERTICAL LINES MARKED IN THE LEFT-HAND MARGIN OF REVISED PARTS LISTING IMAGES. A LINE IS ALSO AT THE LEFT-HAND EDGE OF THE SAME PART NUMBER IN THE NUMERICAL INDEX TO SHOW THE LOCATION OF REVISED INFORMATION.

1A6

640G-III/460DC CABLE AND 648G-III/460DG GRAPPLE SKIDDERS (S.N. 604614-)

ENGINE SERIAL NUMBER PLATE

T137422 -UN-16JAN01



FIRST LINE-ENGINE SERIAL NO. (13 DIGITS)

PE - TORREON, MEXICO
6
068 (6.8 LITERS)
T - TURBOCHARGED
H - AIR-TO-AIR AFTERCOOLED
000000

DEFINES

T137422

ENGINE MANUFACTURING LOCATION
NUMBER OF CYLINDERS
ENGINE DISPLACEMENT
ASPIRATION TYPE

ENGINE SERIAL NUMBER

SECOND LINE-ENGINE MODEL NO. (9 DIGITS)

PE6068HDW64 (W/TORQUE CONVERTER)
PE6068HDW65 (W/O TORQUE CONVERTER)
DW (DAVENPORT WORKS)
64/65

DEFINES

640G/648G
640G/648G
MARKETING UNIT
SPECIFIC APPLICATION

(SPECIFICATIONS AND DESIGN SUBJECT TO CHANGE WITHOUT NOTICE)

1A7

640G-III/460DC CABLE AND 648G-III/460DG GRAPPLE SKIDDERS (S.N. 604614-)

AXLE SERIAL NUMBER PLATE (TEAMMATE)

RXP6496 -UN-01JAN94

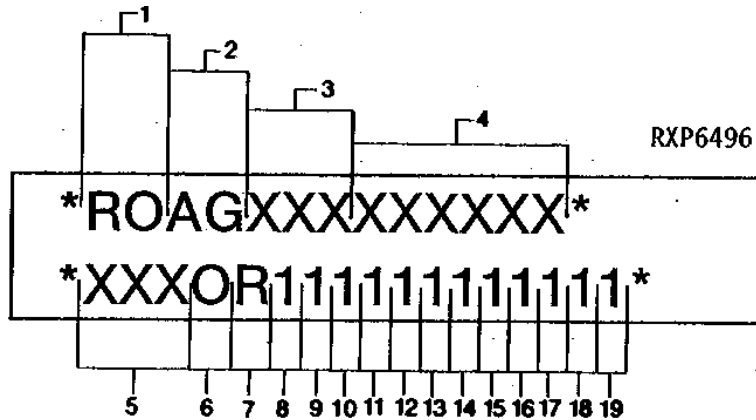

- | | |
|--|--|
| 1. DESIGNATES MANUFACTURING UNIT | RO - JOHN DEERE WATERLOO WORKS |
| 2. DESIGNATES COMPONENT IDENTIFICATION | AG - INBOARD AXLES |
| 3. DESIGNATES CONFIGURATION IDENTITY | 250 - 1200 SERIES |
| | 251 - 1400 SERIES |
| 4. DESIGNATES SERIAL NUMBER | |
| 5. DESIGNATES MASTER MACHINE CODE | |
| 6. DESIGNATES FAMILY CODE | |
| | 2/3 - CONSOLIDATED AXLE |
| 7. DESIGNATES MANUFACTURING UNIT | R - JOHN DEERE WATERLOO WORKS |
| 8. DESIGNATES PRIMARY INPUT ROTATION AND AXLE TRAVEL | 1 - CLOCKWISE; TOWARD INPUT |
| | 2 - CLOCKWISE; AWAY FROM INPUT |
| | 3 - COUNTERCLOCKWISE; TOWARD INPUT |
| | 4 - COUNTERCLOCKWISE; AWAY FROM INPUT |
| 9. DESIGNATES SPIRAL BEVEL REDUCTION | 1 - 4.331:1 |
| | 2 - 4.778:1 |
| | A - 4.333:1 SPECIAL, DISCONNECT |
| | 3 - 5.571:1 |
| 10. DESIGNATES INPUT YOKE - SIZE AND STYLE | 1 - 5C |
| | 2 - 6C |
| | 3 - 58WB |
| | A - SPECIAL, DISCONNECT YOKE |
| 11. DESIGNATES FLANGE TO FLANGE WIDTH | 1 - NONE |
| | 2 - 1300MM (51.2") |
| | 4 - 1700MM (66.9") |
| 12. DESIGNATES INPUT HOUSING AND AUXILIARY BRAKE | 1 - STANDARD INPUT HOUSING, NO AUXILIARY BRAKE |
| | A - SPECIAL, DISCONNECT |

1A8

640G-III/460DC CABLE AND 648G-III/460DG GRAPPLE SKIDDERS (S.N. 604614-)

AXLE SERIAL NUMBER PLATE (TEAMMATE) - CONTINUED

- | | |
|--------------------------------------|--|
| 13. DESIGNATES MOUNTING TYPE | 1 - FIXED MOUNTING |
| | 2 - OSCILLATION, CENTER PIVOT, FRONT BRACKET |
| | A - SPECIAL, OFFSET SUPPORT MOUNTING |
| 14. DESIGNATES BRAKE TYPE | 1 - NO BRAKES |
| | 2 - STANDARD CAPACITY - INDEPENDENT BRAKES |
| | 3 - STANDARD CAPACITY - DUAL BRAKES |
| | 4 - HIGH CAPACITY - INDEPENDENT BRAKES |
| | 5 - HIGH CAPACITY - DUAL BRAKES |
| 15. DESIGNATES DIFFERENTIAL TYPE | 1 - STANDARD |
| | 2 - NO-SPIN |
| | 3 - HYDRAULIC LOCK-CAPTURE SYSTEM |
| 16. DESIGNATES DIFFERENTIAL CASE | 1 - STANDARD |
| | 2 - LOW PROFILE |
| 17. DESIGNATES FINAL DRIVE REDUCTION | 1 - NONE |
| | 2 - 3.714:1 |
| | 3 - 4.800:1 |
| | 4 - 5.500:1 |
| | 5 - 6.000:1 |
| 18. DESIGNATES TRIM | 1 - NOTHING (INTERFACTORY) |
| | 2 - VCI BAG |
| | 3 - PRIMER |
| 19. DESIGNATES MISCELLANEOUS PARTS | 1 - MISCELLANEOUS PARTS (INTERFACTORY) |
| | 2 - MISCELLANEOUS PARTS |

MEMORANDA

1A9

640G-III/460DC CABLE AND 648G-III/460DG GRAPPLE SKIDDERS (S.N. 604614-)

ALPHABETICAL INDEX

GRID		PAGE	GRID		PAGE
	A				
3G4	A/C COMPRESSOR HARDWARE KIT	1832 - 7	1D9	AXLE OSCILLATION LIMITER PLATE (NARROW WHEELS)	0243 - 3
3G3	A/C COMPRESSOR SHAFT SEAL KIT	1832 - 6	1B9	AXLE SHAFT (1200 SERIES)	0201 - 2
2J23	ACCUMULATOR, SERVICE BRAKE (DD)	1063 - 2	1B11	AXLE SHAFT (1400 SERIES)	0201 - 4
2K1	ACCUMULATOR, SERVICE BRAKE (TC)	1063 - 4	1B13	AXLE SHAFT (1400 SERIES) FRONT (SUPER WIDE EXTREME DUTY)	0201 - 5C
2G14	ADAPTER, OIL FILTER (8843) (HDW65)	0410 - 74	1B15	AXLE SHAFT (1400 SERIES) REAR (SUPER WIDE EXTREME DUTY)	0201 - 5G
2D21	ADAPTER, OIL FILTER (8843) (HRW64)	0400 - 74			
2H17	AIR CLEANER	0521 - 2		B	
3G1	AIR CONDITIONER COMPRESSOR	1832 - 4	3H10	BACK-UP ALARM	2004 - 2
3G5	AIR CONDITIONER LINES	1833 - 2	3G18	BAFFLE INSTALLATION	1913 - 6
2D15	AIR CONDITIONING COMPRESSOR BRACKET (7423) (HRW64)	0400 - 68	3J3	BAR, LOCKING, NO WINCH (SF & DF)	3013 - 6
2G8	AIR CONDITIONING COMPRESSOR BRACKET (7423) (HRW65)	0410 - 68	3I23	BAR, LOCKING, WINCH (CABLE)	3013 - 2
2F22	AIR INLET, TURBO (5498) (HDW65)	0410 - 56	3J1	BAR, LOCKING, WINCH (SF & DF)	3013 - 4
2D4	AIR INLET, TURBO (5498) (HRW64)	0400 - 56	3B3	BATTERY (DD)	1671 - 2
2H17	AIR INTAKE	0521 - 2	3B5	BATTERY (TC)	1671 - 4
2B16	AIR INTAKE (17BL) (HDW64)	0400 - 10	3B3	BATTERY CABLE (DD)	1671 - 2
2E9	AIR INTAKE (17BL) (HDW65)	0410 - 10	3B5	BATTERY CABLE (TC)	1671 - 4
3F7	AIR SUSPENSION SEAT BASE	1821 - 4	3B3	BATTERY DISCONNECT SWITCH (DD)	1671 - 2
2D13	AIR TEMPERATURE SENSOR (6723) (HDW64)	0400 - 66	3B5	BATTERY DISCONNECT SWITCH (TC)	1671 - 4
2G6	AIR TEMPERATURE SENSOR (6723) (HDW65)	0410 - 66	2C21	BEARING, CRANKSHAFT THRUST (4712) (HDW64)	0400 - 46
3H10	ALARM, BACK-UP	2004 - 2	2F14	BEARING, CRANKSHAFT THRUST (4712) (HDW65)	0410 - 46
3D7	ALARM, WARNING	1676 - 2	4B7	BEARING, GRAPPLE-ROTATE	3806 - 2
3B7	ALTERNATOR	1672 - 2	2C22	BEARINGS, CONNECTING ROD (4834) (HDW64)	0400 - 48
2D7	ALTERNATOR ADJUSTING STRAP (6256) (HDW64)	0400 - 59	2F15	BEARINGS, CONNECTING ROD (4836) (HDW65)	0410 - 48
2F25	ALTERNATOR ADJUSTING STRAP (6256) (HDW65)	0410 - 59	2C21	BEARINGS, MAIN (4712) (HDW64)	0400 - 46
2D7	ALTERNATOR MOUNTING BRACKETS (6256) (HDW64)	0400 - 59	2F14	BEARINGS, MAIN (4712) (HDW65)	0410 - 46
2F25	ALTERNATOR MOUNTING BRACKETS (6256) (HDW65)	0410 - 59	3L16	BLADE CYLINDER	3265 - 2
3F13	ANTI-CINCH SEAT BELT (3"/76MM)	1821 - 10	3L12	BLADE CYLINDER, HYDRAULIC LINES (CABLE)	3263 - 2
3L19	ARCH (CABLE)	3740 - 2	3L14	BLADE CYLINDER, HYDRAULIC LINES (GRAPPLE)	3263 - 4
4B20	ARCH (DF)	3844 - 4	3L6	BLADE LEVER (CABLE)	3215 - 2
4B18	ARCH (SF)	3844 - 2	3L8	BLADE LEVER (SF & DF)	3215 - 2
4D23	ARCH CYLINDER (DF)	3865 - 6	3L10	BLADE VALVE (CABLE)	3262 - 4
4D23	ARCH CYLINDER (SF)	3865 - 6	3L12	BLADE VALVE, HYDRAULIC LINES (CABLE)	3263 - 2
4D17	ARCH HYDRAULIC LINES (DF)	3863 - 12	3L14	BLADE VALVE, HYDRAULIC LINES (GRAPPLE)	3263 - 4
4D13	ARCH HYDRAULIC LINES (SF)	3863 - 8	4C18	BLADE, SECTION VALVE	3862 - 14
4C24	ARCH SECTION VALVE (MANUAL)	3862 - 20	3L4	BLADE, STACKING	3201 - 2
4D3	ARCH SECTION VALVE (PILOT) (DF)	3862 - 24	2C15	BLOCK, CYLINDER (4633) (PAGE 1) (HDW64)	0400 - 40
4D1	ARCH SECTION VALVE (PILOT) (SF)	3862 - 22	2F8	BLOCK, CYLINDER (4633) (PAGE 1) (HDW65)	0410 - 40
4B7	ARCH, GRAPPLE-ROTATE	3806 - 2	2C19	BLOCK, CYLINDER (4633) (PAGE 3) (HDW64)	0400 - 44
3F9	ARM REST	1821 - 6	2F12	BLOCK, CYLINDER (4633) (PAGE 3) (HDW65)	0410 - 44
2F17	ARM, ROCKER (4905) (HDW65)	0410 - 50	3F19	BLOWER/HEATER ASSEMBLY	1831 - 6
2C24	ARM, ROCKER (4905) (HRW64)	0400 - 50	3F21	BLOWER/HEATER ASSEMBLY (PRESSURIZER)	1831 - 8
3D21	ARTICULATION JOINT	1743 - 2	4B22	BOOM (DF)	3844 - 6
1B8	AXLE ASSEMBLY	0201 - 1	4E1	BOOM CYLINDER (DF)	3865 - 8
1B9	AXLE HOUSING (1200 SERIES)	0201 - 2	4D17	BOOM HYDRAULIC LINES (DF)	3863 - 12
1B11	AXLE HOUSING (1400 SERIES)	0201 - 4	4C24	BOOM SECTION VALVE (MANUAL)	3862 - 20
1B13	AXLE HOUSING (1400 SERIES) FRONT (SUPER WIDE EXTREME DUTY)	0201 - 5C	4D3	BOOM SECTION VALVE (PILOT)	3862 - 24
1B15	AXLE HOUSING (1400 SERIES) REAR (SUPER WIDE EXTREME DUTY)	0201 - 5G	2D15	BRACKET, AIR CONDITIONING COMPRESSOR (7423) (HRW64)	0400 - 68
1D10	AXLE MOUNTING PARTS	0243 - 4	2G8	BRACKET, AIR CONDITIONING COMPRESSOR (7423) (HRW65)	0410 - 68
			2D7	BRACKETS, ALTERNATOR ADJUSTING (6256) (HDW64)	0400 - 59

1A10

640G-III/460DC CABLE AND 648G-III/460DG GRAPPLE SKIDDERS (S.N. 604614-)

ALPHABETICAL INDEX - CONTINUED

GRID		PAGE	GRID		PAGE
2F25	BRACKETS, ALTERNATOR ADJUSTING (6256) (HDW65)	0410 - 59	1C16	CASE, DIFFERENTIAL, OIL LINES (1200 SERIES) (REAR).....	0210 - 12
3K5	BRAKE ASSEMBLY, WINCH, (4000)	3050 - 14	1C19	CASE, DIFFERENTIAL, OIL LINES (1400 SERIES) (FRONT)	0210 - 12C
3K8	BRAKE ASSEMBLY, WINCH, (6000)	3050 - 17	1C18	CASE, DIFFERENTIAL, OIL LINES (1400 SERIES) (REAR).....	0210 - 12B
2J19	BRAKE, PARK	1011 - 4	2I15	CHARGE PUMP (DD)	0651 - 4
2J18	BRAKES (1200 SERIES).....	1011 - 3	2I17	CHARGE PUMP, TORQUE CONVERTER	0651 - 6
2J17	BRAKES, SERVICE (1400 SERIES).....	1011 - 2	2F17	CLAMP, ROCKER ARM SHAFT (4905) (HDW65)	0410 - 50
2C19	BUSHING, CAMSHAFT (4633) (HDW64)	0400 - 44	2C24	CLAMP, ROCKER ARM SHAFT (4905) (HRW64)	0400 - 50
2F12	BUSHING, CAMSHAFT (4633) (HDW65)	0410 - 44	2H17	CLEANER, AIR.....	0521 - 2
3D7	BUZZER, WARNING	1676 - 2	3K5	CLUTCH PLATE, WINCH, BRAKE (4000)	3050 - 14
C					
3E3	CAB COVER	1810 - 4	3K8	CLUTCH PLATE, WINCH, BRAKE (6000)	3050 - 17
3E15	CAB DOOR	1813 - 4	3K3	CLUTCH PLATE, WINCH, INPUT GEAR (4000)	3050 - 12
3C19	CAB ELECTRICAL	1674 - 26	3K12	CLUTCH PLATE, WINCH, INPUT GEAR (6000)	3050 - 21
3E3	CAB MOUNTING	1810 - 4	3H20	COLD START DUMP VALVE (CABLE) (DD)	2162 - 2
3C9	CAB ROOF, ELECTRICAL SYSTEM	1674 - 20	3H22	COLD START DUMP VALVE (CABLE) (TC)	2162 - 4
3E13	CAB SCREENS	1813 - 2	3H24	COLD START DUMP VALVE (GRAPPLE) (DD)	2162 - 6
3C19	CAB SWITCHES	1674 - 26	3I1	COLD START DUMP VALVE (GRAPPLE) (TC)	2162 - 8
3E5	CAB TILT LINES	1811 - 2	2C11	COLD WEATHER STARTING AID (4327) (HDW64)	0400 - 36
3E13	CAB WINDOWS	1813 - 2	2F4	COLD WEATHER STARTING AID (4327) (HDW65)	0410 - 36
3L21	CABLE ROLLERS (CABLE)	3740 - 4	2J8	COLUMN, STEERING	0962 - 2
4B20	CABLE ROLLERS (DF)	3844 - 4	3F23	COMPRESSOR LINES	1832 - 2
4B18	CABLE ROLLERS (SF)	3844 - 2	3G1	COMPRESSOR, AIR CONDITIONER	1832 - 4
3B3	CABLE, BATTERY (DD)	1671 - 2	3F23	CONDENSER LINES	1832 - 2
3B5	CABLE, BATTERY (TC).....	1671 - 4	2L4	CONDITIONER, COOLANT	1369 - 4
3J5	CABLE, WINCH CONTROL LEVER (CABLE)	3015 - 2	2L5	CONDITIONER, COOLANT (CONT.)	1369 - 5
3J7	CABLE, WINCH CONTROL LEVER (GRAPPLE).....	3015 - 3A	2C22	CONNECTING ROD (4834) (HDW64)	0400 - 48
2F17	CAM FOLLOWER (4905) (HDW65)	0410 - 50	2C22	CONNECTING ROD BEARINGS (4834) (HDW64)	0400 - 48
2C24	CAM FOLLOWER (4905) (HRW64)	0400 - 50	2F15	CONNECTING ROD BEARINGS (4836) (HDW65)	0410 - 48
2C19	CAMSHAFT (4633) (HDW64)	0400 - 44	3C23	CONNECTORS, WEATHERPACK	1674 - 30
2F12	CAMSHAFT (4633) (HDW65)	0410 - 44	3F1	CONSOLE, FRONT	1816 - 2
2C19	CAMSHAFT GEAR (4633) (HDW64)	0400 - 44	3F3	CONSOLE, RIGHT SIDE	1816 - 4
2F12	CAMSHAFT GEAR (4633) (HDW65)	0410 - 44	1D22	CONTROLLER, TRANSMISSION	0315 - 4
2C19	CAMSHAFT KEY (4633) (HDW64)	0400 - 44	2I10	CONVERTER, TORQUE	0641 - 2
2F12	CAMSHAFT KEY (4633) (HDW65)	0410 - 44	2L4	COOLANT CONDITIONER	1369 - 4
3E3	CANOPY COVER.....	1810 - 4	2L5	COOLANT CONDITIONER (CONT.).....	1369 - 5
3E3	CANOPY MOUNTING	1810 - 4	2B23	COOLANT HEATER (2694) (HDW64)	0400 - 19
3E17	CANOPY SCREENS	1813 - 6	2E16	COOLANT HEATER (2694) (HDW65)	0410 - 19
3E17	CANOPY WINDOWS	1813 - 6	2D6	COOLER, ENGINE OIL (5945) (HDW64)	0400 - 58
2I3	CAP, FUEL (CABLE)	0564 - 2	2F24	COOLER, ENGINE OIL (5945) (HDW65)	0410 - 58
2I7	CAP, FUEL (DF)	0564 - 6	2H11	COOLER, HYDRAULIC LINES (DD).....	0512 - 2
2I5	CAP, FUEL (SF).....	0564 - 4	2H13	COOLER, HYDRAULIC LINES (TC).....	0512 - 4
2C15	CAP,MAIN BEARING (4633) (HDW64)	0400 - 40	2G23	COOLER, TRANSMISSION OIL (DD).....	0510 - 2
2F8	CAP,MAIN BEARING (4633) (HDW65)	0410 - 40	2H3	COOLER, TRANSMISSION OIL (TC).....	0510 - 6
3C11	CARRIER, ELECTRICAL SYSTEM (DD)	1674 - 22	2H11	COOLING MOTOR (DD)	0512 - 2
3C13	CARRIER, ELECTRICAL SYSTEM (DD) (CONT.).....	1674 - 23A	2H13	COOLING MOTOR (TC)	0512 - 4
3C15	CARRIER, ELECTRICAL SYSTEM (TC)	1674 - 24	2G23	COOLING SYSTEM (DD)	0510 - 2
3C17	CARRIER, ELECTRICAL SYSTEM (TC) (CONT.)	1674 - 25A	2H1	COOLING SYSTEM (DD) (CONT.).....	0510 - 4
4D7	CASE DRAIN HYDRAULIC LINES (GRAPPLE).....	3863 - 2	2H3	COOLING SYSTEM (TC).....	0510 - 6
1C12	CASE, DIFFERENTIAL (1200 SERIES)	0210 - 10	2H5	COOLING SYSTEM (TC) (CONT.)	0510 - 8
1C14	CASE, DIFFERENTIAL (1400 SERIES)	0210 - 11A	2L8	COOLSCAN PLUS TEST KIT	1369 - 8
1C17	CASE, DIFFERENTIAL, OIL LINES (1200 SERIES) (FRONT)	0210 - 12A	1D3	COUPLING SHAFT (DANA)	0225 - 4
			3E3	COVER, CAB	1810 - 4
			3E3	COVER, CANOPY	1810 - 4
			1C2	COVER, DIFFERENTIAL CASE, FRONT (1200 SERIES).....	0210 - 4
			1C8	COVER, DIFFERENTIAL CASE, FRONT (1400 SERIES).....	0210 - 7E

1A11

640G-III/460DC CABLE AND 648G-III/460DG GRAPPLE SKIDDERS (S.N. 604614-)

ALPHABETICAL INDEX - CONTINUED

GRID	PAGE	GRID	PAGE
1C4	COVER, DIFFERENTIAL CASE, REAR (1200 SERIES).....	2C22	CYLINDER LINER O-RING KIT (4834) (HCQ80).....
	0210 - 6		0400 - 48
1C6	COVER, DIFFERENTIAL CASE, REAR (1400 SERIES).....	2C22	CYLINDER LINER O-RING KIT (4834) (HDW64).....
	0210 - 7C		0400 - 48
1G24	COVER, DRIVE DAMPENER	2F15	CYLINDER LINER O-RING KIT (4836) (HDW65)
	0370 - 3		0410 - 48
2C13	COVER, INJ. PUMP ACCESS (4436) (HDW64)	4D23	CYLINDER, ARCH (DF).....
	0400 - 38		3865 - 6
2F6	COVER, INJ. PUMP ACCESS (4436) (HDW65)	4D23	CYLINDER, ARCH (SF).....
	0410 - 38		3865 - 6
3J3	COVER, NO WINCH (SF & DF)	3L16	CYLINDER, BLADE
	3013 - 6		3265 - 2
2B8	COVER, ROCKER ARM (1144) (HDW64)	4E1	CYLINDER, BOOM (DF)
	0400 - 2		3865 - 8
2E1	COVER, ROCKER ARM (1144) (HDW65)	3E5	CYLINDER, CAB TILT.....
	0410 - 2		1811 - 2
2B21	COVER, THERMOSTAT (2154) (HRW64)	4D21	CYLINDER, GRAPPLE (115", 10.4 SQ.FT.).....
	0400 - 15		3865 - 4
2E14	COVER, THERMOSTAT (2154) (HRW65)	4D19	CYLINDER, GRAPPLE (123", 12.5 SQ.FT)
	0410 - 15		3865 - 2
2C13	COVER, TIMING GEAR (4436) (HDW64)	3E5	CYLINDER, ROPS TILT
	0400 - 38		1811 - 2
2F6	COVER, TIMING GEAR (4436) (HDW65)	2J14	CYLINDER, STEERING.....
	0410 - 38		0965 - 2
3J1	COVER, WINCH (SF & DF).....	3E7	CYLINDER, TILT HYDRAULICS
	3013 - 4		1811 - 4
3I23	COVER, WINCH (CABLE).....		
	3013 - 2		
3J14	COVER, WINCH (4000).....		
	3041 - 2		
3J16	COVER, WINCH (6000).....		
	3041 - 4		
3J20	COVER, WINCH, CLUTCH & INPUT SHAFT(4000)		
	3050 - 4		
3K13	COVER, WINCH, CLUTCH & INPUT SHAFT(6000)		
	3050 - 22		
3G14	COVERS, ENGINE FRAME.....		
	1913 - 2		
3G16	COVERS, ENGINE FRAME (W/ WINCH SHAFT)		
	1913 - 4		
3G14	COVERS, EQUIPMENT FRAME.....		
	1913 - 2		
3G16	COVERS, EQUIPMENT FRAME (W/ WINCH SHAFT) ..		
	1913 - 4		
1E12	COVERS, TRANSMISSION.....		
	0342 - 2		
2C21	CRANKSHAFT (4712) (HDW64)		
	0400 - 46		
2F14	CRANKSHAFT (4712) (HDW65)		
	0410 - 46		
2C21	CRANKSHAFT GEAR (4712) (HDW64)		
	0400 - 46		
2F14	CRANKSHAFT GEAR (4712) (HDW65)		
	0410 - 46		
2D13	CRANKSHAFT POSITION SENSOR (6723) (HDW64)		
	0400 - 66		
2G6	CRANKSHAFT POSITION SENSOR (6723) (HDW65)		
	0410 - 66		
2B11	CRANKSHAFT PULLEY (1321) (HDW64)		
	0400 - 5		
2E4	CRANKSHAFT PULLEY (1321) (HDW65)		
	0410 - 5		
2C21	CRANKSHAFT THRUST BEARING (4712) (HDW64)		
	0400 - 46		
2F14	CRANKSHAFT THRUST BEARING (4712) (HDW65)		
	0410 - 46		
4B16	CROSS HEAD DAMPERS, GRAPPLE		
	3843 - 2		
4E3	CROSSOVER RELIEF ASSEMBLY, ROTATE MOTOR		
	3867 - 2		
2C15	CYLINDER BLOCK (4633) (PAGE 1) (HDW64)		
	0400 - 40		
2F8	CYLINDER BLOCK (4633) (PAGE 1) (HDW65)		
	0410 - 40		
2C19	CYLINDER BLOCK (4633) (PAGE 3) (HDW64)		
	0400 - 44		
2F12	CYLINDER BLOCK (4633) (PAGE 3) (HDW65)		
	0410 - 44		
2C17	CYLINDER BLOCK FITTINGS (4633) (PAGE 2) (HDW64)		
	0400 - 42		
2F10	CYLINDER BLOCK FITTINGS (4633) (PAGE 2) (HDW65)		
	0410 - 42		
3G20	CYLINDER GUARDS, ARCH AND BOOM.....		
	1913 - 8		
2D2	CYLINDER HEAD (5120) (HDW64)		
	0400 - 54		
2F20	CYLINDER HEAD (5120) (HDW65)		
	0410 - 54		
2D2	CYLINDER HEAD GASKET (5120) (HDW64)		
	0400 - 54		
2F20	CYLINDER HEAD GASKET (5120) (HDW65)		
	0410 - 54		

D

1G24	DAMPENER, DRIVE	0370 - 3
2K24	DASH LABELS.....	1320 - 17
2K9	DECALS AND LABELS, ENGLISH	1320 - 2
2K11	DECALS AND LABELS, ENGLISH (CONT.).....	1320 - 4
2K13	DECALS AND LABELS, FRENCH	1320 - 6
2K17	DECALS AND LABELS, GERMAN	1320 - 10
2L1	DECALS AND LABELS, ITALIAN	1320 - 18
2K21	DECALS AND LABELS, PORTUGUESE	1320 - 14
2K19	DECALS AND LABELS, RUSSIAN	1320 - 12
2K15	DECALS AND LABELS, SPANISH	1320 - 8
4B15	DELIMBING GRATE (DF ARCH W/O WINCH OR ROLLER)	3840 - 11
2L9	DIESELSCAN TEST KIT	1369 - 9
1C20	DIFFERENTIAL BEARING QUILLS (1200 SERIES).....	0210 - 13
1C21	DIFFERENTIAL BEARING QUILLS (1400 SERIES).....	0210 - 14
1C12	DIFFERENTIAL CASE (1200 SERIES).....	0210 - 10
1C14	DIFFERENTIAL CASE (1400 SERIES).....	0210 - 11A
1C2	DIFFERENTIAL CASE COVER, FRONT (1200 SERIES).....	0210 - 4
1C8	DIFFERENTIAL CASE COVER, FRONT (1400 SERIES).....	0210 - 7E
1C4	DIFFERENTIAL CASE COVER, REAR (1200 SERIES).....	0210 - 6
1C6	DIFFERENTIAL CASE COVER, REAR (1400 SERIES).....	0210 - 7C
1C17	DIFFERENTIAL CASE OIL LINES (1200 SERIES) (FRONT)	0210 - 12A
1C16	DIFFERENTIAL CASE OIL LINES (1200 SERIES) (REAR).....	0210 - 12
1C19	DIFFERENTIAL CASE OIL LINES (1400 SERIES) (FRONT)	0210 - 12C
1C18	DIFFERENTIAL CASE OIL LINES (1400 SERIES) (REAR).....	0210 - 12B
1C22	DIFFERENTIAL HOUSING (1200 SERIES)	0210 - 16
1C24	DIFFERENTIAL HOUSING (1400 SERIES)	0210 - 18
1D12	DIFFERENTIAL LOCK FILTER (DD)	0263 - 2
1D14	DIFFERENTIAL LOCK FILTER (TC)	0263 - 6
1D12	DIFFERENTIAL LOCK HYDRAULIC LINES (DD)	0263 - 2
1D14	DIFFERENTIAL LOCK HYDRAULIC LINES (TC).....	0263 - 6
1D16	DIFFERENTIAL LOCK HYDRAULIC LINES (TC) (CONT.)	0263 - 8
1D12	DIFFERENTIAL LOCK PUMP (DD)	0263 - 2
1D14	DIFFERENTIAL LOCK PUMP (TC).....	0263 - 6
2C10	DIPSTICK, OIL (4002) (HDW64).....	0400 - 34
2F3	DIPSTICK, OIL (4002) (HDW65).....	0410 - 34

1A12

640G-III/460DC CABLE AND 648G-III/460DG GRAPPLE SKIDDERS (S.N. 604614-)

ALPHABETICAL INDEX - CONTINUED

GRID	PAGE	GRID	PAGE			
2I24	DISCONNECT, TRANSMISSION	0752 - 2	3D23	ENGINE FRAME DOORS	1746 - 2	
4C3	DIVIDER, GRAPPLE FLOW	3860 - 16	3G14	ENGINE FRAME GUARDS	1913 - 2	
3E15	DOOR, CAB	1813 - 4	3G16	ENGINE FRAME GUARDS (W/ WINCH SHAFT)	1913 - 4	
3D23	DOOR, ENGINE FRAME	1746 - 2	2H21	ENGINE MOUNTS (DD)	0540 - 2	
1D7	DOUBLE UNIVERSAL JOINT	0225 - 8	2H23	ENGINE MOUNTS (TC).....	0540 - 4	
1G24	DRIVE DAMPENER	0370 - 3	2C15	ENGINE OIL BY-PASS VALVE (4633) (HDW64)	0400 - 40	
1G24	DRIVE DAMPENER COVER	0370 - 3	2F8	ENGINE OIL BY-PASS VALVE (4633) (HDW65)	0410 - 40	
1G5	DRIVE, TRANSMISSION PTO (WITH WINCH), INTERNAL PARTS (TC)	0350 - 44	2L3	ENGINE OIL, TORQ-GARD.....	1369 - 3	
1G5	DRIVE, WINCH (TC)	0350 - 44	2L4	ENGINE PARTS LUBRICANTS.....	1369 - 4	
1D1	DRIVELINE LAYOUT	0225 - 2	2L5	ENGINE PARTS LUBRICANTS (CONT.)	1369 - 5	
2I24	DRIVESHAFT, DISCONNECT ENGINE TO TRANSMISSION	0752 - 2	3G12	ENGINE SIDE SHIELD	1912 - 2	
1E1	DRIVESHAFT, ENGINE TO TRANSMISSION (DD).....	0325 - 5	2D13	ENGINE SPEED, SENSOR (6723) (HDW64)	0400 - 66	
1D24	DRIVESHAFT, ENGINE TO TRANSMISSION (TC)	0325 - 2	2G6	ENGINE SPEED, SENSOR (6723) (HDW65)	0410 - 66	
2I24	DRIVESHAFT, ENGINE TO TRANSMISSION, DISCONNECT	0752 - 2	1E1	ENGINE TO TRANSMISSION DRIVESHAFT (DD)	0325 - 5	
1D5	DRIVESHAFT, FRONT AXLE TO TRANSMISSION.....	0225 - 6	1D24	ENGINE TO TRANSMISSION DRIVESHAFT (TC)	0325 - 2	
1D1	DRIVESHAFT, LAYOUT	0225 - 2	3B15	ENGINE, ELECTRICAL SYSTEM (DD)	1674 - 6	
1D3	DRIVESHAFT, REAR AXLE TO BEARING SUPPORT ..	0225 - 4	3B17	ENGINE, ELECTRICAL SYSTEM (DD)(CONT.).....	1674 - 7A	
1D7	DRIVESHAFT, TRANSM. TO BEARING SUPPORT ..	0225 - 8	3B19	ENGINE, ELECTRICAL SYSTEM (TC).....	1674 - 8	
4E6	DRIVESHAFT, WINCH TO TRANSMISSION (DD)	4025 - 2	3B21	ENGINE, ELECTRICAL SYSTEM (TC)(CONT.)	1674 - 9A	
4E7	DRIVESHAFT, WINCH TO TRANSMISSION (TC).....	4025 - 4	2K9	ENGLISH LABELS AND DECALS	1320 - 2	
1D1	DRIVETRAIN	0225 - 2	2K11	ENGLISH LABELS AND DECALS (CONT.)	1320 - 4	
3J14	DRUM, WINCH (4000).....	3041 - 2	3D15	EQUIPMENT FRAME (CABLE).....	1742 - 2	
3J16	DRUM, WINCH (6000).....	3041 - 4	3D19	EQUIPMENT FRAME (DF)	1742 - 6	
1B4	DUAL WHEELS	0110 - 4	3D17	EQUIPMENT FRAME (SF)	1742 - 4	
3E11	DUCT, OVERHEAD	1812 - 4	3G14	EQUIPMENT FRAME COVERS	1913 - 2	
3E11	DUCT, VERTICAL LEFTHAND	1812 - 4	3G16	EQUIPMENT FRAME COVERS (W/ WINCH SHAFT) ..	1913 - 4	
E				3G14	EQUIPMENT FRAME GUARDS	1913 - 2
2G21	ECU	0500 - 2	3G16	EQUIPMENT FRAME GUARDS (W/ WINCH SHAFT) ..	1913 - 4	
2D23	EGR (8901) (HRW64)	0400 - 76	2D23	EXHAUST GAS RECIRCULATION (8901) (HRW64) ..	0400 - 76	
2G16	EGR (8903) (HRW65)	0410 - 76	2G16	EXHAUST GAS RECIRCULATION (8903) (HRW65) ..	0410 - 76	
3H12	ELECTRIC HORN	2004 - 4	2B24	EXHAUST MANIFOLD (2873).....	0400 - 20	
3C19	ELECTRICAL SYSTEM, CAB	1674 - 26	2E17	EXHAUST MANIFOLD (2876) (HDW67).....	0410 - 20	
3C9	ELECTRICAL SYSTEM, CAB ROOF	1674 - 20	2H19	EXHAUST SYSTEM.....	0530 - 2	
3C11	ELECTRICAL SYSTEM, CARRIER (DD)	1674 - 22	2D2	EXHAUST VALVE (5120) (HDW64)	0400 - 54	
3C13	ELECTRICAL SYSTEM, CARRIER (DD) (CONT.).....	1674 - 23A	2F20	EXHAUST VALVE (5120) (HDW65)	0410 - 54	
3C15	ELECTRICAL SYSTEM, CARRIER (TC)	1674 - 24	3H6	EXTINGUISHER, FIRE	2003 - 2	
3C17	ELECTRICAL SYSTEM, CARRIER (TC) (CONT.)	1674 - 25A	F			
3B15	ELECTRICAL SYSTEM, ENGINE (DD)	1674 - 6	2D20	FAN DRIVE PULLEY (8717) (HRW64).....	0400 - 73	
3B17	ELECTRICAL SYSTEM, ENGINE (DD)(CONT.).....	1674 - 7A	2G13	FAN DRIVE PULLEY (8717) (HRW65).....	0410 - 73	
3B19	ELECTRICAL SYSTEM, ENGINE (TC).....	1674 - 8	2H7	FAN GUARDS	0511 - 2	
3B21	ELECTRICAL SYSTEM, ENGINE (TC)(CONT.)	1674 - 9A	2G23	FAN SHROUD, COOLING SYSTEM (DD)	0510 - 2	
3B13	ELECTRICAL SYSTEM, FUEL SENDER	1674 - 4	2H3	FAN SHROUD, COOLING SYSTEM (TC)	0510 - 6	
3D5	ELECTRICAL SYSTEM, GRAPPLE PILOT CONTROL ..	1674 - 36	2H11	FAN, ENGINE (DD)	0512 - 2	
3C7	ELECTRICAL SYSTEM, HYDRAULIC RESERVOIR ..	1674 - 18	2H13	FAN, ENGINE (TC)	0512 - 4	
3C3	ELECTRICAL SYSTEM, INTERFACE (DD)	1674 - 14	2K24	FAULT LAMP LABEL.....	1320 - 17	
3C5	ELECTRICAL SYSTEM, INTERFACE (TC)	1674 - 16	3D10	FENDER (GRAPPLE)	1740 - 3	
3C7	ELECTRICAL SYSTEM, START AID	1674 - 18	1F5	FIFTH STAGE ASSEMBLY, TRANSMISSION (DD).....	0350 - 18	
3B23	ELECTRICAL SYSTEM, TRANSMISSION (DD).....	1674 - 10	1F7	FIFTH STAGE ASSEMBLY, TRANSMISSION (TC).....	0350 - 20	
3C1	ELECTRICAL SYSTEM, TRANSMISSION (TC)	1674 - 12	2B10	FILL, OIL (1201) (HDW64)	0400 - 4	
2G14	ELEMENT, OIL FILTER (8843) (HDW65)	0410 - 74	2E3	FILL, OIL (1201) (HDW65)	0410 - 4	
2D21	ELEMENT, OIL FILTER (8843) (HRW64)	0400 - 74	1D12	FILTER, DIFFERENTIAL LOCK (DD)	0263 - 2	
2K23	EMBLEM, SLOW MOVING VEHICLE	1320 - 16	1D14	FILTER, DIFFERENTIAL LOCK (TC)	0263 - 6	
2G21	ENGINE CONTROL UNIT	0500 - 2	2D17	FILTER, FUEL PRIMARY (8169)	0400 - 70	
2H11	ENGINE FAN (DD).....	0512 - 2	3I19	FILTER, HYDRAULIC OIL	2164 - 2	
2H13	ENGINE FAN (TC).....	0512 - 4	3I19	FILTER, HYDRAULIC RESERVOIR	2164 - 2	
2H7	ENGINE FAN GUARDS.....	0511 - 2	2G14	FILTER, OIL (8843) (HDW65)	0410 - 74	
3D11	ENGINE FRAME	1741 - 2				
3G14	ENGINE FRAME COVERS	1913 - 2				
3G16	ENGINE FRAME COVERS (W/ WINCH SHAFT).....	1913 - 4				

1A13

640G-III/460DC CABLE AND 648G-III/460DG GRAPPLE SKIDDERS (S.N. 604614-)

ALPHABETICAL INDEX - CONTINUED

GRID	PAGE	GRID	PAGE
2D21	FILTER, OIL (8843) (HRW64) 0400 - 74	2E7	FUEL INJECTION LINES (169Z) (HDW65) 0410 - 8
1G18	FILTER, TRANSMISSION OIL (DD) 0363 - 2	2B14	FUEL INJECTION PUMP (169Z) (HDW64) 0400 - 8
1G22	FILTER, TRANSMISSION OIL (TC) 0363 - 6	2E7	FUEL INJECTION PUMP (169Z) (HDW65) 0410 - 8
1B19	FINAL DRIVE RING GEAR (FRONT AND REAR) (1200 SERIES)..... 0201 - 8	2I3	FUEL SENDER (CABLE)..... 0564 - 2
1B17	FINAL DRIVE RING GEAR (FRONT AND REAR) (1400 SERIES)..... 0201 - 6	2I7	FUEL SENDER (DF) 0564 - 6
1B21	FINAL DRIVE RING GEAR (FRONT AND REAR) (1400 SERIES) (EXTREME DUTY) 0201 - 10	2I5	FUEL SENDER (SF) 0564 - 4
1B23	FINAL DRIVE RING GEAR (FRONT AND REAR) (1400 SERIES)(SUPER WIDE EXTREME DUTY)..... 0201 - 11A	3B13	FUEL SENDER, ELECTRICAL SYSTEM 1674 - 4
2C3	FINAL FILTER,FUEL (35DZ) (HDW64) 0400 - 26	2I3	FUEL TANK (CABLE) 0564 - 2
2E21	FINAL FILTER,FUEL (35DZ) (HDW65) 0410 - 26	2I7	FUEL TANK (DF) 0564 - 6
3H6	FIRE EXTINGUISHER 2003 - 2	2I5	FUEL TANK (SF) 0564 - 4
1E14	FIRST STAGE ASSEMBLY, TRANSMISSION (DD) 0350 - 2	2I1	FUEL TANK LINES 0563 - 2
1E16	FIRST STAGE ASSEMBLY, TRANSMISSION (TC)..... 0350 - 4	2C7	FUEL TRANSFER PUMP (3713) (HDW64) 0400 - 30
2C17	FITTINGS, CYLINDER BLOCK (4633) (PAGE 2) (HDW64) 0400 - 42	2E25	FUEL TRANSFER PUMP (3713) (HDW65) 0410 - 30
2F10	FITTINGS, CYLINDER BLOCK (4633) (PAGE 2) (HDW65) 0410 - 42	3C21	FUSE PANEL 1674 - 28
3E9	FLOORMAT (CAB FLOOR) 1812 - 2		G
4C3	FLOW DIVIDER, GRAPPLE 3860 - 16	2D2	GASKET, CYLINDER HEAD (5120) (HDW64) 0400 - 54
2L8	FLUID ANALYSIS PRODUCTS (COOLANT) 1369 - 8	2F20	GASKET, CYLINDER HEAD (5120) (HDW65) 0410 - 54
2L9	FLUID ANALYSIS PRODUCTS (DIESEL) 1369 - 9	2F17	GASKET, ROCKER ARM (4905) (HDW65) 0410 - 50
2L6	FLUID ANALYSIS PRODUCTS (ENGINE) 1369 - 6	2C24	GASKET, ROCKER ARM (4905) (HRW64) 0400 - 50
2B13	FLYWHEEL (1504) (HDW64) 0400 - 7	2B8	GASKET, ROCKER ARM COVER (1144) (HDW64) 0400 - 2
2E6	FLYWHEEL (1529) (HDW65) 0410 - 7	2E1	GASKET, ROCKER ARM COVER (1144) (HDW65) 0410 - 2
2E5	FLYWHEEL HOUSING (1411) (HDW65) 0410 - 6	2C8	GASKET, THERMOSTAT HOUSING (3917) (HDW64)..... 0400 - 32
2B12	FLYWHEEL HOUSING (1454) (HDW64) 0400 - 6	2F1	GASKET, THERMOSTAT HOUSING (3917) (HDW65)..... 0410 - 32
1F1	FOURTH STAGE ASSEMBLY, TRANSMISSION (DD) .. 0350 - 14	1F19	GEAR CASE, TRANSMISSION PTO (W/WINCH)(DD) 0350 - 34
1F3	FOURTH STAGE ASSEMBLY, TRANSMISSION (TC) .. 0350 - 16	1F23	GEAR CASE, TRANSMISSION PTO(W/WINCH)(TC) 0350 - 38
3D11	FRAME, ENGINE 1741 - 2	1G1	GEAR CASE, TRANSMISSION WITHOUT PTO (WITHOUT WINCH) (TC) 0350 - 40
3D15	FRAME, EQUIPMENT (CABLE) 1742 - 2	2C19	GEAR, CAMSHAFT (4633) (HDW64) 0400 - 44
3D19	FRAME, EQUIPMENT (DF)..... 1742 - 6	2F12	GEAR, CAMSHAFT (4633) (HDW65) 0410 - 44
3D17	FRAME, EQUIPMENT (SF)..... 1742 - 4	2C21	GEAR, CRANKSHAFT (4712) (HDW64) 0400 - 46
4B3	FRAME, GRAPPLE (10.4 SQ FT) (115") 3803 - 2	2F14	GEAR, CRANKSHAFT (4712) (HDW65) 0410 - 46
4B5	FRAME, GRAPPLE (12.5 SQ FT) (123") 3803 - 4	2D1	GEAR, OIL PUMP (5024) (HDW64) 0400 - 52
2K13	FRENCH LABELS AND DECALS 1320 - 6	2F19	GEAR, OIL PUMP (5024) (HDW65) 0410 - 52
1D5	FRONT AXLE YOKE 0225 - 6	2C5	GEAR, UPPER IDLER (3612) (HDW64)..... 0400 - 28
3F1	FRONT CONSOLE..... 1816 - 2	2E23	GEAR, UPPER IDLER (3612) (HDW65)..... 0410 - 28
3D13	FRONT GUARDS, ENGINE FRAME..... 1741 - 4	2I17	GEARS, TORQUE CONVERTER 0651 - 6
2C5	FRONT PLATE (3612) (HDW64)..... 0400 - 28	2K17	GERMAN LABELS AND DECALS 1320 - 10
2E23	FRONT PLATE (3612) (HDW65)..... 0410 - 28	4C8	GRAPPLE CONTROL VALVE (MANUAL) (DF) 3862 - 4
1E4	FRONT TRANSMISSION HOUSING (DD) 0341 - 6	4C6	GRAPPLE CONTROL VALVE (MANUAL) (SF) 3862 - 2
1E6	FRONT TRANSMISSION HOUSING (TC) 0341 - 8	4C12	GRAPPLE CONTROL VALVE (PILOT) (DF) 3862 - 8
3E21	FRONT WINDSHIELD WASHER 1814 - 2	4C10	GRAPPLE CONTROL VALVE (PILOT) (SF) 3862 - 6
3E21	FRONT WINDSHIELD WIPER 1814 - 2	4B16	GRAPPLE CROSS HEAD DAMPERS AND PINS 3843 - 2
2I3	FUEL CAP (CABLE) 0564 - 2	4D21	GRAPPLE CYLINDER (115", 10.4 SQ.FT.) 3865 - 4
2I7	FUEL CAP (DF) 0564 - 6	4D19	GRAPPLE CYLINDER (123", 12.5 SQ.FT.) 3865 - 2
2I5	FUEL CAP (SF) 0564 - 4	4D15	GRAPPLE CYLINDER LINES (SF & DF) 3863 - 10
2C3	FUEL FILTER GASKET KIT (35DZ) (HDW64) 0400 - 26	4B3	GRAPPLE FRAME (10.4 SQ FT) (115")..... 3803 - 2
2E21	FUEL FILTER GASKET KIT (35DZ) (HDW65) 0410 - 26	4B5	GRAPPLE FRAME (12.5 SQ FT) (123") 3803 - 4
2G1	FUEL FILTER LINES (6391) (HDW65) 0410 - 60	4B3	GRAPPLE HEAD (10.4 SQ FT) (115") 3803 - 2
2D8	FUEL FILTER LINES (6391) (HRW64) 0400 - 60	4B5	GRAPPLE HEAD (12.5 SQ FT) (123") 3803 - 4
2C3	FUEL FILTER, FINAL (35DZ) (HDW64) 0400 - 26	4B11	GRAPPLE LEVER (DF, MANUAL) 3815 - 4
2E21	FUEL FILTER, FINAL (35DZ) (HDW65) 0410 - 26	4B13	GRAPPLE LEVER (DF, PILOT) 3815 - 6
2G10	FUEL FILTER, PRIMARY (8169) 0410 - 70	4B9	GRAPPLE LEVER (SF, MANUAL) 3815 - 2
2B14	FUEL INJECTION LINES (169Z) (HDW64) 0400 - 8		

1A14

640G-III/460DC CABLE AND 648G-III/460DG GRAPPLE SKIDDERS (S.N. 604614-)

ALPHABETICAL INDEX - CONTINUED

GRID	PAGE	GRID	PAGE
4B13	GRAPPLE LEVER (SF, PILOT).....	3815 - 6	
4B11	GRAPPLE LEVER LINKAGE (DF, MANUAL).....	3815 - 4	
4B13	GRAPPLE LEVER LINKAGE (DF, PILOT).....	3815 - 6	
4B9	GRAPPLE LEVER LINKAGE (SF, MANUAL).....	3815 - 2	
4B13	GRAPPLE LEVER LINKAGE (SF, PILOT).....	3815 - 6	
4E3	GRAPPLE ROTATE MOTOR.....	3867 - 2	
3D4	GRAPPLE ROTATE SWITCH.....	1674 - 35	
4B3	GRAPPLE TONGS (10.4 SQ FT) (115").....	3803 - 2	
4B5	GRAPPLE TONGS (12.5 SQ FT) (123").....	3803 - 4	
4D11	GRAPPLE VALVE HYDRAULIC LINES, PILOT CONTROL (DF).....	3863 - 6	
4D9	GRAPPLE VALVE HYDRAULIC LINES, PILOT CONTROL (SF).....	3863 - 4	
4B7	GRAPPLE-ROTATE BEARING.....	3806 - 2	
4B7	GRAPPLE-ROTATE MOTOR PARTS.....	3806 - 2	
4B7	GRAPPLE-ROTATE YOKE.....	3806 - 2	
4B24	GRATE (DF).....	3847 - 2	
4B15	GRATE, DELIMBING (DF ARCH W/O WINCH OR ROLLER).....	3840 - 11	
4B15	GRATE, UPPER (DF ARCH W/O WINCH OR ROLLER).....	3840 - 11	
3G22	GRILLE.....	1921 - 2	
3L12	GUARD, BLADE CYLINDER (CABLE).....	3263 - 2	
3L14	GUARD, BLADE CYLINDER (GRAPPLE).....	3263 - 4	
2H7	GUARD, FAN.....	0511 - 2	
3G20	GUARDS, CYLINDER, ARCH AND BOOM.....	1913 - 8	
3G14	GUARDS, ENGINE FRAME.....	1913 - 2	
3G16	GUARDS, ENGINE FRAME (W/ WINCH SHAFT).....	1913 - 4	
3G14	GUARDS, EQUIPMENT FRAME.....	1913 - 2	
3G16	GUARDS, EQUIPMENT FRAME (W/ WINCH SHAFT) ..	1913 - 4	
3D13	GUARDS, FRONT, ENGINE FRAME.....	1741 - 4	
H			
3G4	HARDWARE KIT, A/C COMPRESSOR (R134A REFRIGERANT).....	1832 - 7	
2F22	HARNES, WIRING (5498) (HDW65).....	0410 - 56	
2D4	HARNES, WIRING (5498) (HRW64).....	0400 - 56	
2D19	HARNES, WIRING (8493) (HRW64).....	0400 - 72	
2G12	HARNES, WIRING (8493) (HRW65).....	0410 - 72	
2D2	HEAD, CYLINDER (5120) (HDW64).....	0400 - 54	
2F20	HEAD, CYLINDER (5120) (HDW65).....	0410 - 54	
4B3	HEAD, GRAPPLE (10.4 SQ FT) (115").....	3803 - 2	
4B5	HEAD, GRAPPLE (12.5 SQ FT) (123").....	3803 - 4	
2G14	HEADER, OIL FILTER (8843) (HDW65).....	0410 - 74	
2D21	HEADER, OIL FILTER (8843) (HRW64).....	0400 - 74	
3E11	HEADLINER WITH DUCTING.....	1812 - 4	
3F17	HEATER LINES.....	1831 - 4	
3F19	HEATER/BLOWER ASSEMBLY.....	1831 - 6	
3F21	HEATER/BLOWER ASSEMBLY (PRESSURIZER).....	1831 - 8	
2B23	HEATER, COOLANT (2694) (HDW64).....	0400 - 19	
2E16	HEATER, COOLANT (2694) (HDW65).....	0410 - 19	
3G10	HOOD.....	1911 - 2	
3E11	HOOK, CLOTHES.....	1812 - 4	
3H12	HORN, ELECTRIC.....	2004 - 4	
4C1	HOSE, SUPPORT.....	3860 - 10	
2B25	HOSE, VENTILATING (2911) (HDW64).....	0400 - 22	
2E18	HOSE, VENTILATING (2911) (HDW65).....	0410 - 22	
1B9	HOUSING, AXLE (1200 SERIES).....	0201 - 2	
1B11	HOUSING, AXLE (1400 SERIES).....	0201 - 4	
1B13	HOUSING, AXLE (1400 SERIES) FRONT (SUPER WIDE EXTREME DUTY).....	0201 - 5C	
1B15	HOUSING, AXLE (1400 SERIES) REAR (SUPER WIDE EXTREME DUTY).....	0201 - 5G	
1C22	HOUSING, DIFFERENTIAL (1200 SERIES).....	0210 - 16	
1C24	HOUSING, DIFFERENTIAL (1400 SERIES).....	0210 - 18	
2E5	HOUSING, FLYWHEEL (1411) (HDW65).....	0410 - 6	
2B12	HOUSING, FLYWHEEL (1454) (HDW64).....	0400 - 6	
1E4	HOUSING, FRONT TRANSMISSION (DD).....	0341 - 6	
1E6	HOUSING, FRONT TRANSMISSION (TC).....	0341 - 8	
2D1	HOUSING, OIL PUMP (5024) (HDW64).....	0400 - 52	
2F19	HOUSING, OIL PUMP (5024) (HDW65).....	0410 - 52	
1E8	HOUSING, REAR TRANSMISSION (DD).....	0341 - 10	
1E10	HOUSING, REAR TRANSMISSION (TC).....	0341 - 12	
2C8	HOUSING, THERMOSTAT (3917) (HDW64).....	0400 - 32	
2F1	HOUSING, THERMOSTAT (3917) (HDW65).....	0410 - 32	
2I17	HOUSING, TORQUE CONVERTER.....	0651 - 6	
3J14	HOUSING, WINCH, (4000).....	3041 - 2	
3J16	HOUSING, WINCH, (6000).....	3041 - 4	
3G7	HVAC PRECLEANER.....	1835 - 2	
4D17	HYDRAULIC LINES, ARCH (DF).....	3863 - 12	
4D13	HYDRAULIC LINES, ARCH (SF).....	3863 - 8	
3L12	HYDRAULIC LINES, BLADE CYLINDER (CABLE).....	3263 - 2	
3L14	HYDRAULIC LINES, BLADE CYLINDER (GRAPPLE)	3263 - 4	
3L12	HYDRAULIC LINES, BLADE VALVE (CABLE).....	3263 - 2	
3L14	HYDRAULIC LINES, BLADE VALVE (GRAPPLE).....	3263 - 4	
4D17	HYDRAULIC LINES, BOOM (DF).....	3863 - 12	
4D7	HYDRAULIC LINES, CASE DRAIN (GRAPPLE).....	3863 - 2	
2H11	HYDRAULIC LINES, COOLER (DD).....	0512 - 2	
2H13	HYDRAULIC LINES, COOLER (TC).....	0512 - 4	
1D12	HYDRAULIC LINES, DIFFERENTIAL LOCK (DD).....	0263 - 2	
1D14	HYDRAULIC LINES, DIFFERENTIAL LOCK (TC).....	0263 - 6	
1D16	HYDRAULIC LINES, DIFFERENTIAL LOCK (TC) (CONT.).....	0263 - 8	
3I3	HYDRAULIC LINES, MAIN (CABLE) (DD).....	2163 - 2	
3I5	HYDRAULIC LINES, MAIN (CABLE) (DD) (CONT.).....	2163 - 3A	
3I7	HYDRAULIC LINES, MAIN (CABLE) (TC).....	2163 - 4	
3I9	HYDRAULIC LINES, MAIN (CABLE) (TC) (CONT.).....	2163 - 5A	
3I11	HYDRAULIC LINES, MAIN (GRAPPLE) (DD).....	2163 - 6	
3I13	HYDRAULIC LINES, MAIN (GRAPPLE) (DD) (CONT.).....	2163 - 7A	
3I15	HYDRAULIC LINES, MAIN (GRAPPLE) (TC).....	2163 - 8	
3I17	HYDRAULIC LINES, MAIN (GRAPPLE) (TC) (CONT.).....	2163 - 9A	
2K6	HYDRAULIC LINES, PARK BRAKE VALVE.....	1163 - 2	
4D11	HYDRAULIC LINES, PILOT CONTROL GRAPPLE VALVE (DF).....	3863 - 6	
4D9	HYDRAULIC LINES, PILOT CONTROL GRAPPLE VALVE (SF).....	3863 - 4	
3I3	HYDRAULIC LINES, RESERVOIR (CABLE) (DD).....	2163 - 2	
3I5	HYDRAULIC LINES, RESERVOIR (CABLE) (DD) (CONT.).....	2163 - 3A	
3I7	HYDRAULIC LINES, RESERVOIR (CABLE) (TC).....	2163 - 4	
3I9	HYDRAULIC LINES, RESERVOIR (CABLE) (TC) (CONT.).....	2163 - 5A	
3I11	HYDRAULIC LINES, RESERVOIR (GRAPPLE) (DD).....	2163 - 6	
3I13	HYDRAULIC LINES, RESERVOIR (GRAPPLE) (DD) (CONT.).....	2163 - 7A	
3I15	HYDRAULIC LINES, RESERVOIR (GRAPPLE) (TC).....	2163 - 8	
3I17	HYDRAULIC LINES, RESERVOIR (GRAPPLE) (TC) (CONT.).....	2163 - 9A	
4D7	HYDRAULIC LINES, ROTATE MOTOR (GRAPPLE).....	3863 - 2	
2J10	HYDRAULIC LINES, STEERING (DD).....	0963 - 2	

1A15

640G-III/460DC CABLE AND 648G-III/460DG GRAPPLE SKIDDERS (S.N. 604614-)

ALPHABETICAL INDEX - CONTINUED

<i>GRID</i>		<i>PAGE</i>	<i>GRID</i>		<i>PAGE</i>
2J12	HYDRAULIC LINES, STEERING (TC)	0963 - 4	2D2	INTAKE VALVE (5120) (HDW64)	0400 - 54
3E5	HYDRAULIC LINES, TILT, CAB	1811 - 2	2F20	INTAKE VALVE (5120) (HDW65)	0410 - 54
3E5	HYDRAULIC LINES, TILT, ROPS	1811 - 2	2H17	INTAKE, AIR	0521 - 2
2K6	HYDRAULIC LINES, TRANSMISSION/BRAKE	1163 - 2	2B16	INTAKE, AIR (17BL) (HDW64)	0400 - 10
1G18	HYDRAULIC LINES, TRANSMISSION/COOLER (DD)	0363 - 2	2E9	INTAKE, AIR (17BL) (HDW65)	0410 - 10
1G20	HYDRAULIC LINES, TRANSMISSION/COOLER (TC)	0363 - 4	2B18	INTAKE, OIL PUMP (1981) (HDW64)	0400 - 12
1G22	HYDRAULIC LINES, TRANSMISSION/COOLER (TC) (CONT.)	0363 - 6	2E11	INTAKE, OIL PUMP (1981) (HDW65)	0410 - 12
3K21	HYDRAULIC LINES, WINCH (4000)	3060 - 8	3C3	INTERFACE, ELECTRICAL SYSTEM (DD)	1674 - 14
3L1	HYDRAULIC LINES, WINCH (4000) PRESSURE REDUCING	3060 - 12	3C5	INTERFACE, ELECTRICAL SYSTEM (TC)	1674 - 16
3K23	HYDRAULIC LINES, WINCH (6000)	3060 - 10	2L1	ITALIAN LABELS AND DECALS	1320 - 18
3I19	HYDRAULIC OIL FILTER	2164 - 2			
3I3	HYDRAULIC PUMP LINES (CABLE) (DD)	2163 - 2		J	
3I5	HYDRAULIC PUMP LINES (CABLE) (DD) (CONT.)	2163 - 3A	3D21	JOINT, ARTICULATION	1743 - 2
3I7	HYDRAULIC PUMP LINES (CABLE) (TC)	2163 - 4			
3I9	HYDRAULIC PUMP LINES (CABLE) (TC) (CONT.)	2163 - 5A		K	
3I11	HYDRAULIC PUMP LINES (GRAPPLE) (DD)	2163 - 6	3C19	KEY SWITCH	1674 - 26
3I13	HYDRAULIC PUMP LINES (GRAPPLE) (DD) (CONT.)	2163 - 7A	2C19	KEY, CAMSHAFT (4633) (HDW64)	0400 - 44
3I15	HYDRAULIC PUMP LINES (GRAPPLE) (TC)	2163 - 8	2F12	KEY, CAMSHAFT (4633) (HDW65)	0410 - 44
3I17	HYDRAULIC PUMP LINES (GRAPPLE) (TC) (CONT.)	2163 - 9A	3C19	KEY, IGNITION	1674 - 26
1D12	HYDRAULIC PUMP, DIFFERENTIAL LOCK (DD)	0263 - 2	3D1	KIT, LEAD WIRE	1674 - 32
1D14	HYDRAULIC PUMP, DIFFERENTIAL LOCK (TC)	0263 - 6	2J8	KNOB, STEERING WHEEL	0962 - 2
3H18	HYDRAULIC PUMP, MAIN	2161 - 2			
3I19	HYDRAULIC RESERVOIR	2164 - 2		L	
3I19	HYDRAULIC RESERVOIR FILTER	2164 - 2	2C2	LABEL, STARTER (3042) (HDW64)	0400 - 24
3I3	HYDRAULIC RESERVOIR LINES (CABLE) (DD)	2163 - 2	2E20	LABEL, STARTER (3058) (HDW65)	0410 - 24
3I5	HYDRAULIC RESERVOIR LINES (CABLE) (DD) (CONT.)	2163 - 3A	2K9	LABELS AND DECALS, ENGLISH	1320 - 2
3I7	HYDRAULIC RESERVOIR LINES (CABLE) (TC)	2163 - 4	2K11	LABELS AND DECALS, ENGLISH (CONT.)	1320 - 4
3I9	HYDRAULIC RESERVOIR LINES (CABLE) (TC) (CONT.)	2163 - 5A	2K13	LABELS AND DECALS, FRENCH	1320 - 6
3I11	HYDRAULIC RESERVOIR LINES (GRAPPLE) (DD)	2163 - 6	2K17	LABELS AND DECALS, GERMAN	1320 - 10
3I13	HYDRAULIC RESERVOIR LINES (GRAPPLE) (DD) (CONT.)	2163 - 7A	2L1	LABELS AND DECALS, ITALIAN	1320 - 18
3I15	HYDRAULIC RESERVOIR LINES (GRAPPLE) (TC)	2163 - 8	2K21	LABELS AND DECALS, PORTUGUESE	1320 - 14
3I17	HYDRAULIC RESERVOIR LINES (GRAPPLE) (TC) (CONT.)	2163 - 9A	2K19	LABELS AND DECALS, RUSSIAN	1320 - 12
3C7	HYDRAULIC RESERVOIR, ELECTRICAL SYSTEM	1674 - 18	2K15	LABELS AND DECALS, SPANISH	1320 - 8
3C7	HYDRAULIC TEMPERATURE SENSOR	1674 - 18	2K24	LABELS, DASH	1320 - 17
			2K24	LAMP, FAULT LABEL	1320 - 17
			3F15	LATCH, SEAT SWIVEL	1821 - 12
			3D1	LEAD WIRE KIT	1674 - 32
3C19	IGNITION KEY	1674 - 26	3L6	LEVER MOUNT (CABLE)	3215 - 2
2I22	INCHING PEDAL (DD)	0715 - 4	3L8	LEVER MOUNT, BLADE (SF & DF)	3215 - 4
2I22	INCHING PEDAL LINKAGE (DD)	0715 - 4	4B11	LEVER MOUNT, GRAPPLE (DF, MANUAL)	3815 - 4
4C14	INLET SECTION RELIEF VALVE (MANUAL)	3862 - 10	4B13	LEVER MOUNT, GRAPPLE (DF, PILOT)	3815 - 6
4C16	INLET SECTION RELIEF VALVE (PILOT)	3862 - 12	4B9	LEVER MOUNT, GRAPPLE (SF, MANUAL)	3815 - 2
4C14	INLET SECTION VALVE (MANUAL)	3862 - 10	4B13	LEVER MOUNT, GRAPPLE (SF, PILOT)	3815 - 6
4C16	INLET SECTION VALVE (PILOT)	3862 - 12	3L6	LEVER, BLADE (CABLE)	3215 - 2
2D5	INLET, WATER PUMP (5722) (HDW64)	0400 - 57	3L8	LEVER, BLADE (SF & DF)	3215 - 4
2F23	INLET, WATER PUMP (5728) (HDW65)	0410 - 57	4B11	LEVER, GRAPPLE (DF, MANUAL)	3815 - 4
1C2	INPUT QUILL, FRONT (1200 SERIES)	0210 - 4	4B13	LEVER, GRAPPLE (DF, PILOT)	3815 - 6
1C8	INPUT QUILL, FRONT (1400 SERIES)	0210 - 7E	4B9	LEVER, GRAPPLE (SF, MANUAL)	3815 - 2
1C4	INPUT QUILL, REAR (1200 SERIES)	0210 - 6	4B13	LEVER, GRAPPLE (SF, PILOT)	3815 - 6
1C6	INPUT QUILL, REAR (1400 SERIES)	0210 - 7C	4B11	LEVER, LINKAGE, GRAPPLE (DF, MANUAL)	3815 - 4
1B25	INPUT YOKE (FRONT AND REAR) (1200 AND 1400 SERIES)	0210 - 2	4B13	LEVER, LINKAGE, GRAPPLE (DF, PILOT)	3815 - 6
3H4	INSIDE REAR VIEW MIRROR	2002 - 2	4B9	LEVER, LINKAGE, GRAPPLE (SF, MANUAL)	3815 - 2
3G18	INSTALLATION, BAFFLE	1913 - 6	4B13	LEVER, LINKAGE, GRAPPLE (SF, PILOT)	3815 - 6
			3F15	LEVER, SEAT LUMBAR SUPPORT CONTROL	1821 - 12
			3F15	LEVER, SEAT SLIDE CONTROL	1821 - 12

1A16

640G-III/460DC CABLE AND 648G-III/460DG GRAPPLE SKIDDERS (S.N. 604614-)

ALPHABETICAL INDEX - CONTINUED

GRID		PAGE	GRID		PAGE
3F15	LEVER, SEAT SWIVEL CONTROL	1821 - 12	3I23	LOCKING BAR, WINCH (CABLE).....	3013 - 2
3J5	LEVER, WINCH CONTROL (CABLE).....	3015 - 2	3J1	LOCKING BAR, WINCH (SF & DF)	3013 - 4
3J7	LEVER, WINCH CONTROL (GRAPPLE)	3015 - 3A	3E11	LOUVER, HEADLINER	1812 - 4
2D25	LIFT STRAPS (9801) (HRW64).....	0400 - 78	2L4	LUBRICANTS, ENGINE PARTS	1369 - 4
2G18	LIFT STRAPS (9801) (HRW65).....	0410 - 78	2L5	LUBRICANTS, ENGINE PARTS (CONT.).....	1369 - 5
3E11	LIGHTS, OVERHEAD DOME	1812 - 4	2L10	LUBRICATION SYSTEM, REMOTE	1370 - 2
3B9	LIGHTS, 2 FRONT/2 REAR	1673 - 2			
3B11	LIGHTS, 4 FRONT/4 REAR	1673 - 4		M	
3E19	LIMB RISERS.....	1813 - 8			
2C22	LINER, CYLINDER (4834) (HDW64)	0400 - 48	2D13	MAGNETIC PICK-UP SENSOR (6723) (HDW64)	0400 - 66
2F15	LINER, CYLINDER (4836) (HDW65)	0410 - 48	2G6	MAGNETIC PICK-UP SENSOR (6723) (HDW65)	0410 - 66
2J23	LINES, ACCUMULATOR SERVICE BRAKE (DD)	1063 - 2	2C15	MAIN BEARING CAP (4633) (HDW64)	0400 - 40
2K1	LINES, ACCUMULATOR SERVICE BRAKE (TC)	1063 - 4	2F8	MAIN BEARING CAP (4633) (HDW65)	0410 - 40
3G5	LINES, AIR CONDITIONER.....	1833 - 2	2C21	MAIN BEARINGS (4712) (HDW64)	0400 - 46
3L12	LINES, BLADE CYLINDER (CABLE)	3263 - 2	2F14	MAIN BEARINGS (4712) (HDW65)	0410 - 46
3L14	LINES, BLADE CYLINDER (GRAPPLE).....	3263 - 4	3I3	MAIN HYDRAULIC LINES (CABLE) (DD)	2163 - 2
3L12	LINES, BLADE VALVE (CABLE).....	3263 - 2	3I5	MAIN HYDRAULIC LINES (CABLE) (DD) (CONT.)	2163 - 3A
3L14	LINES, BLADE VALVE (GRAPPLE)	3263 - 4	3I7	MAIN HYDRAULIC LINES (CABLE) (TC).....	2163 - 4
3F23	LINES, COMPRESSOR	1832 - 2	3I9	MAIN HYDRAULIC LINES (CABLE) (TC) (CONT.)	2163 - 5A
3F23	LINES, CONDENSER	1832 - 2	3I11	MAIN HYDRAULIC LINES (GRAPPLE) (DD).....	2163 - 6
1D12	LINES, DIFFERENTIAL LOCK PUMP (DD)	0263 - 2	3I13	MAIN HYDRAULIC LINES (GRAPPLE) (DD) (CONT.)	2163 - 7A
1D14	LINES, DIFFERENTIAL LOCK PUMP (TC)	0263 - 6	3I15	MAIN HYDRAULIC LINES (GRAPPLE) (TC)	2163 - 8
1D16	LINES, DIFFERENTIAL LOCK PUMP (TC) (CONT.)	0263 - 8	3I17	MAIN HYDRAULIC LINES (GRAPPLE) (TC) (CONT.)	2163 - 9A
2G1	LINES, FUEL FILTER (6391) (HDW65)	0410 - 60	3H18	MAIN HYDRAULIC PUMP.....	2161 - 2
2D8	LINES, FUEL FILTER (6391) (HRW64)	0400 - 60	2D13	MANIFOLD AIR PRESSURE SENSOR (6723) (HDW64)	0400 - 66
2B14	LINES, FUEL INJECTION (169Z) (HDW64).....	0400 - 8	2G6	MANIFOLD AIR PRESSURE SENSOR (6723) (HDW65)	0410 - 66
2E7	LINES, FUEL INJECTION (169Z) (HDW65).....	0410 - 8	2B24	MANIFOLD, EXHAUST (2873)	0400 - 20
2I1	LINES, FUEL TANK.....	0563 - 2	2E17	MANIFOLD, EXHAUST (2876) (HDW67)	0410 - 20
4D15	LINES, GRAPPLE CYLINDER (SF & DF)	3863 - 10	4C5	MANIFOLD, ROTATE	3860 - 19
3F17	LINES, HEATER.....	1831 - 4	3H4	MIRROR, INSIDE REAR VIEW	2002 - 2
3I3	LINES, MAIN HYDRAULIC (CABLE) (DD)	2163 - 2	3D7	MONITOR.....	1676 - 2
3I5	LINES, MAIN HYDRAULIC (CABLE) (DD) (CONT.)	2163 - 3A	2H11	MOTOR, COOLING (DD).....	0512 - 2
3I7	LINES, MAIN HYDRAULIC (CABLE) (TC)	2163 - 4	2H13	MOTOR, COOLING (TC).....	0512 - 4
3I9	LINES, MAIN HYDRAULIC (CABLE) (TC) (CONT.)	2163 - 5A	4E3	MOTOR, GRAPPLE ROTATE	3867 - 2
3I11	LINES, MAIN HYDRAULIC (GRAPPLE) (DD)	2163 - 6	3J13	MOUNTING HARDWARE, WINCH	3041 - 1
3I13	LINES, MAIN HYDRAULIC (GRAPPLE) (DD) (CONT.)	2163 - 7A	3E3	MOUNTING, CAB.....	1810 - 4
3I15	LINES, MAIN HYDRAULIC (GRAPPLE) (TC).....	2163 - 8	3E3	MOUNTING, CANOPY.....	1810 - 4
3I17	LINES, MAIN HYDRAULIC (GRAPPLE) (TC) (CONT.)	2163 - 9A	2H15	MOUNTING, SPEED CONTROL PEDAL	0515 - 2
4D11	LINES, PILOT CONTROL GRAPPLE VALVE (DF)	3863 - 6	1D22	MOUNTING, TCU.....	0315 - 4
4D9	LINES, PILOT CONTROL GRAPPLE VALVE (SF)	3863 - 4	2I12	MOUNTING, TORQUE CONVERTER.....	0641 - 4
3G5	LINES, PRESSURIZER	1833 - 2	1G7	MOUNTING, TRANSMISSION CONTROL VALVE(DD)	0360 - 2
2J23	LINES, SERVICE BRAKE (DD).....	1063 - 2	1G9	MOUNTING, TRANSMISSION CONTROL VALVE(TC)	0360 - 4
2K1	LINES, SERVICE BRAKE (TC)	1063 - 4	1D22	MOUNTING, TRANSMISSION CONTROLLER.....	0315 - 4
2J10	LINES, STEERING (DD)	0963 - 2	2H21	MOUNTS, ENGINE (DD)	0540 - 2
2J12	LINES, STEERING (TC)	0963 - 4	2H23	MOUNTS, ENGINE (TC)	0540 - 4
2K6	LINES, TRANSMISSION/BRAKE.....	1163 - 2	1E12	MOUNTS, TRANSMISSION.....	0342 - 2
1G18	LINES, TRANSMISSION/COOLER (DD).....	0363 - 2	2H19	MUFFLER.....	0530 - 2
1G20	LINES, TRANSMISSION/COOLER (TC)	0363 - 4			
1G22	LINES, TRANSMISSION/COOLER (TC) (CONT.)	0363 - 6		N	
2D10	LINES, TURBOCHARGER OIL (65MY) (HDW64)	0400 - 62	3J3	NO WINCH COVER (SF & DF)	3013 - 6
2G3	LINES, TURBOCHARGER OIL (65MY) (HDW65)	0410 - 62			
3J9	LINKAGE (4000) WINCH.....	3015 - 4			
3J11	LINKAGE (6000) WINCH.....	3015 - 6			
2I22	LINKAGE, INCHING PEDAL (DD).....	0715 - 4			
2I20	LINKAGE, TRANSMISSION DISCONNECT CONTROL	0715 - 2			
3J3	LOCKING BAR, NO WINCH (SF & DF)	3013 - 6			

1A17

640G-III/460DC CABLE AND 648G-III/460DG GRAPPLE SKIDDERS (S.N. 604614-)

ALPHABETICAL INDEX - CONTINUED

GRID		PAGE	GRID		PAGE
	O				
2G23	OIL COOLER (DD).....	0510 - 2	2E11	OPTION 1981 OIL PAN (HDW65)	0410 - 12
2H3	OIL COOLER (TC).....	0510 - 6	2B20	OPTION 2001 WATERPUMP PULLEY (HRW64)	0400 - 14
2D6	OIL COOLER, ENGINE (5945) (HDW64)	0400 - 58	2E13	OPTION 2001 WATERPUMP PULLEY (HRW65)	0410 - 14
2F24	OIL COOLER, ENGINE (5945) (HDW65)	0410 - 58	2B21	OPTION 2154 THERMOSTAT COVER (HRW64)	0400 - 15
2C10	OIL DIPSTICK (4002) (HDW64)	0400 - 34	2E14	OPTION 2154 THERMOSTAT COVER (HRW65)	0410 - 15
2F3	OIL DIPSTICK (4002) (HDW65)	0410 - 34	2B22	OPTION 2255 THERMOSTAT (HRW64)	0400 - 16
2B10	OIL FILL (1201) (HDW64)	0400 - 4	2E15	OPTION 2255 THERMOSTAT (HRW65)	0410 - 16
2E3	OIL FILL (1201) (HDW65)	0410 - 4	2B23	OPTION 2694 COOLANT HEATER (HDW64)	0400 - 19
2G14	OIL FILTER (8843) (HDW65)	0410 - 74	2E16	OPTION 2694 COOLANT HEATER (HDW65)	0410 - 19
2D21	OIL FILTER (8843) (HRW64)	0400 - 74	2B24	OPTION 2873 EXHAUST MANIFOLD	0400 - 20
2G14	OIL FILTER HEADER (8843) (HDW65)	0410 - 74	2E17	OPTION 2876 EXHAUST MANIFOLD (HDW67)	0410 - 20
2D21	OIL FILTER HEADER (8843) (HRW64)	0400 - 74	2B25	OPTION 2911 VENTILATING SYSTEM (HDW64)	0400 - 22
1C17	OIL LINES, DIFFERENTIAL CASE (1200 SERIES) (FRONT)	0210 - 12A	2E18	OPTION 2911 VENTILATING SYSTEM (HDW65)	0410 - 22
1C16	OIL LINES, DIFFERENTIAL CASE (1200 SERIES) (REAR).....	0210 - 12	2C2	OPTION 3042 STARTER 12V (HDW64)	0400 - 24
1C19	OIL LINES, DIFFERENTIAL CASE (1400 SERIES) (FRONT)	0210 - 12C	2E20	OPTION 3058 STARTER 12V (HDW65)	0410 - 24
1C18	OIL LINES, DIFFERENTIAL CASE (1400 SERIES) (REAR).....	0210 - 12B	2C3	OPTION 35DZ FUEL FILTER (HDW64)	0400 - 26
2D10	OIL LINES, TURBOCHARGER (65MY) (HDW64)	0400 - 62	2E21	OPTION 35DZ FUEL FILTER (HDW65)	0410 - 26
2G3	OIL LINES, TURBOCHARGER (65MY) (HDW65)	0410 - 62	2C5	OPTION 3612 FRONT PLATE & IDLER GEAR (HDW64)	0400 - 28
2B18	OIL PAN (1981) (HDW64)	0400 - 12	2E23	OPTION 3612 FRONT PLATE & IDLER GEAR (HDW65)	0410 - 28
2E11	OIL PAN (1981) (HDW65)	0410 - 12	2C7	OPTION 3713 FUEL TRANSFER PUMP (HDW64)	0400 - 30
2D16	OIL PRESSURE SENSOR (7635) (HRW64).....	0400 - 69	2E25	OPTION 3713 FUEL TRANSFER PUMP (HDW65)	0410 - 30
2G9	OIL PRESSURE SENSOR (7635) (HRW65).....	0410 - 69	2C8	OPTION 3917 THERMOSTAT HOUSING (HDW64)	0400 - 32
2D16	OIL PRESSURE SWITCH (7635) (HRW64).....	0400 - 69	2F1	OPTION 3917 THERMOSTAT HOUSING (HDW65)	0410 - 32
2G9	OIL PRESSURE SWITCH (7635) (HRW65).....	0410 - 69	2C10	OPTION 4002 OIL DIPSTICK (HDW64)	0400 - 34
2D1	OIL PUMP (5024) (HDW64)	0400 - 52	2F3	OPTION 4002 OIL DIPSTICK (HDW65)	0410 - 34
2F19	OIL PUMP (5024) (HDW65)	0410 - 52	2C11	OPTION 4327 STARTING AID (HDW64)	0400 - 36
2B18	OIL PUMP INTAKE (1981) (HDW64)	0400 - 12	2F4	OPTION 4327 STARTING AID (HDW65)	0410 - 36
2E11	OIL PUMP INTAKE (1981) (HDW65)	0410 - 12	2C13	OPTION 4436 TIMING GEAR COVER (HDW64).....	0400 - 38
2L6	OILSCAN PLUS TEST KIT	1369 - 6	2F6	OPTION 4436 TIMING GEAR COVER (HDW65).....	0410 - 38
2B8	OPTION 1144 ROCKER ARM COVER (HDW64)	0400 - 2	2C15	OPTION 4633 CYLINDER BLOCK (PAGE 1) (HDW64)	0400 - 40
2E1	OPTION 1144 ROCKER ARM COVER (HDW65)	0410 - 2	2F8	OPTION 4633 CYLINDER BLOCK (PAGE 1) (HDW65)	0410 - 40
2B10	OPTION 1201 OIL FILL (HDW64).....	0400 - 4	2C19	OPTION 4633 CYLINDER BLOCK (PAGE 3) (HDW64)	0400 - 44
2E3	OPTION 1201 OIL FILL (HDW65).....	0410 - 4	2F12	OPTION 4633 CYLINDER BLOCK (PAGE 3) (HDW65)	0410 - 44
2B11	OPTION 1321 CRANKSHAFT PULLEY (HDW64)	0400 - 5	2C17	OPTION 4633 CYLINDER BLOCK FITTINGS (PAGE 2) (HDW64)	0400 - 42
2E4	OPTION 1321 CRANKSHAFT PULLEY (HDW65)	0410 - 5	2F10	OPTION 4633 CYLINDER BLOCK FITTINGS (PAGE 2) (HDW65)	0410 - 42
2E5	OPTION 1411 FLYWHEEL HOUSING (HDW65)	0410 - 6	2C21	OPTION 4712 CRANKSHAFT AND BEARINGS (HDW64)	0400 - 46
2B12	OPTION 1454 FLYWHEEL HOUSING (HDW64)	0400 - 6	2F14	OPTION 4712 CRANKSHAFT AND BEARINGS (HDW65)	0410 - 46
2B13	OPTION 1504 FLYWHEEL (HDW64)	0400 - 7	2C22	OPTION 4834 PISTON, CONNECTING ROD, CYLINDER LINER (HDW64)	0400 - 48
2E6	OPTION 1529 FLYWHEEL (HDW65)	0410 - 7	2F15	OPTION 4836 PISTON, CONNECTING ROD, CYLINDER LINER (HDW65)	0410 - 48
2B14	OPTION 169Z FUEL INJECTION PUMP (HDW64)	0400 - 8	2F17	OPTION 4905 ROCKER ARMS AND PUSH RODS (HDW65)	0410 - 50
2E7	OPTION 169Z FUEL INJECTION PUMP (HDW65)	0410 - 8	2C24	OPTION 4905 ROCKER ARMS AND PUSH RODS (HRW64)	0400 - 50
2B16	OPTION 17BL AIR INTAKE (HDW64)	0400 - 10	2D1	OPTION 5024 OIL PUMP (HDW64)	0400 - 52
2E9	OPTION 17BL AIR INTAKE (HDW65)	0410 - 10	2F19	OPTION 5024 OIL PUMP (HDW65)	0410 - 52
2B18	OPTION 1981 OIL PAN (HDW64)	0400 - 12	2D2	OPTION 5120 CYLINDER HEAD (HDW64)	0400 - 54